

# U-T40 U-T40E

## Floor Cover Plate Two Post Vehicle Lift 底板双柱举升机



(CE: ONLY FOR U-T40E)

### U-T40



Dual manual  
Lock Release  
双边手动解锁

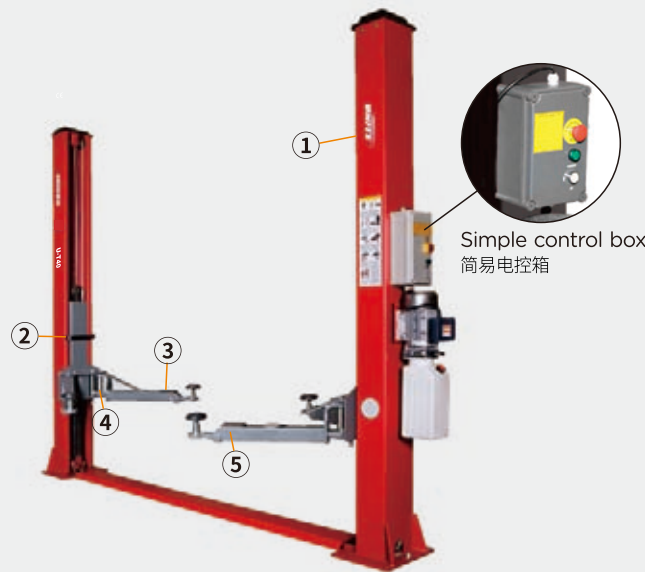

Simple control box  
简易电控箱

### U-T40E



Electric Lock  
Release  
电动解锁  
Electromagnetic  
Lowering  
电磁下降



Make according to CE norms  
按照CE标准制造

## SAFETY FEATURES 安全特点



① Height limit  
switch  
上限位开关



② Car door protection  
车门保护垫



③ Arm pad  
托臂垫



④ Automatic all-steel  
arm-locking device  
全自动全钢锁臂装置

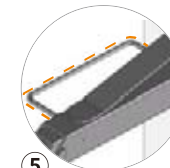

⑤ Foot Protection  
Device  
防压脚装置



Dual hydraulic  
cylinders  
双液压缸设置



Safety valve for  
anti-explosion of  
hydraulic system  
安全阀加强安全保护



Synchronization  
cables  
同步钢丝绳

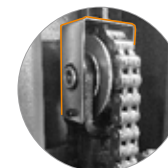

Chain protector  
防脱链装置



Easy access grease  
nipple design  
外置润滑油加注口

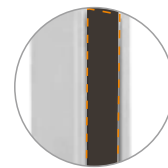

Dust protection  
防尘布

## STANDARD 标准配置



Aluminum motor  
铝电机, 耐用, 散热好



Adjustable lifting  
pad to three(3)  
heights  
可调橡胶托垫3节高度

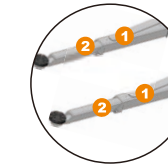

Two stage arms  
2节臂

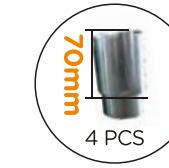

Adapters  
增高柱

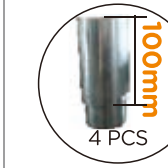

Optional: Adapters  
(选配) 增高柱

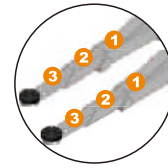

Optional: three  
stage arms  
(选配) 3节臂

## DIMENSION 尺寸参数

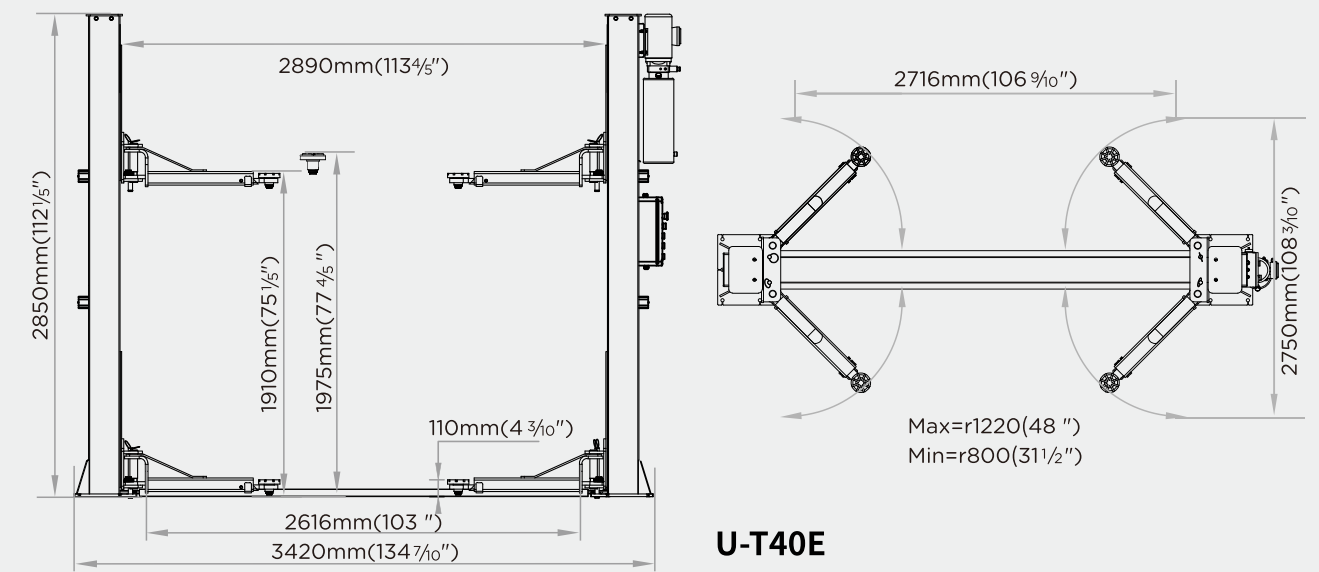

## TECHNICAL DATA 技术参数

MODEL 型号	U-T40	U-T40E
Capacity 举升重量	4.0 Ton	4.0 Ton
Lifting height 举升高度	1910mm(75 1/5")	1910mm(75 1/5")
Min height 托臂高度	110mm(4 3/10")	110mm(4 3/10")
Max car width 通车宽度	2616mm(103")	2616mm(103")
Power supply 电源功率	220V 1PH 50/60Hz 2.2KW 220/380V 3PH 50/60Hz 2.2KW	220V 1PH 50/60Hz 2.2KW 220/380V 3PH 50/60Hz 2.2KW
Shipping Information 装运信息	Loading QTY : 30 units/20' CTNR 2940*455*670mm (628 kg/units)	Loading QTY : 30 units/20' CTNR 2940*455*750mm (628 kg/units)