

U-T60EB

Arch Type Clear Floor Two Post Vehicle Lift

龙门双柱举升机

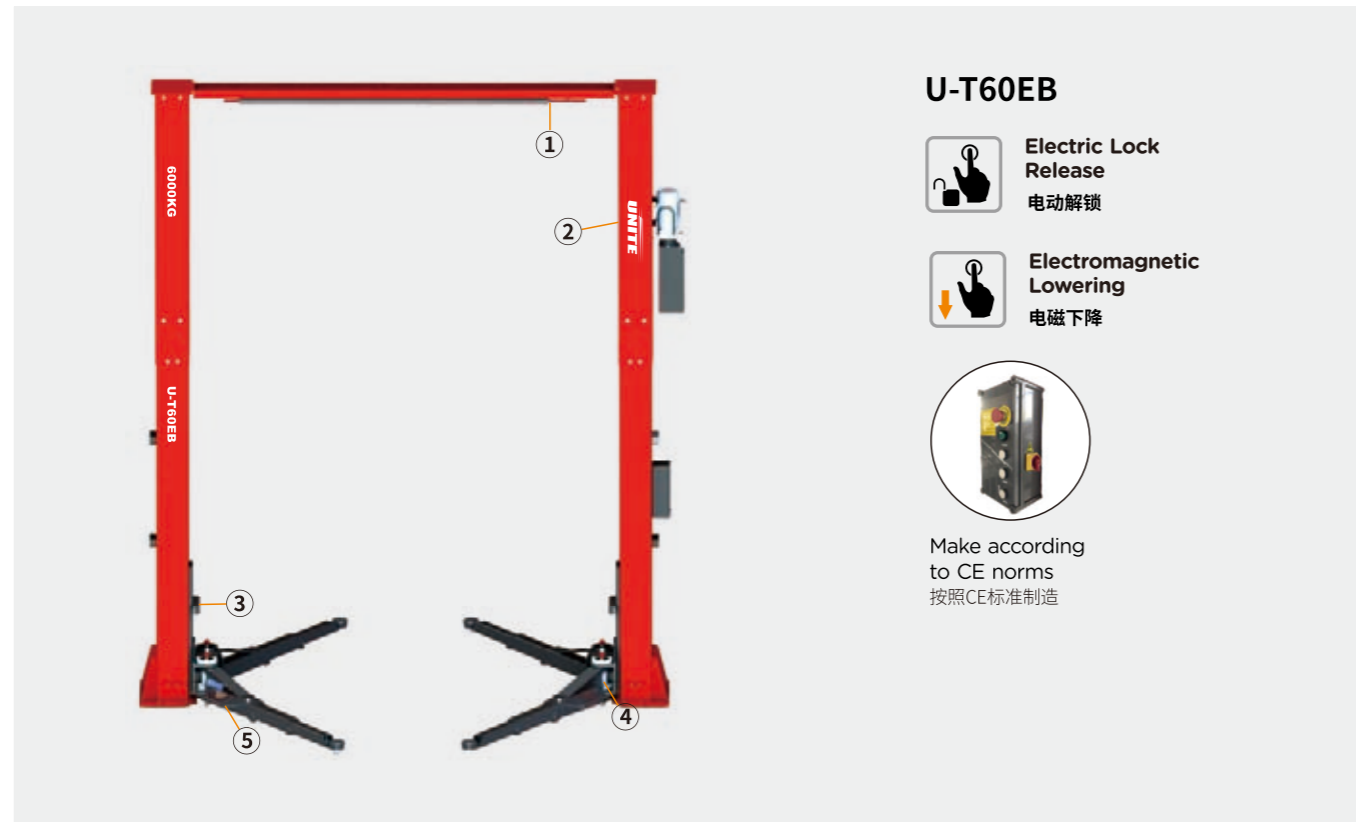

U-T60EB

- Electric Lock Release**
电动解锁
- Electromagnetic Lowering**
电磁下降
- Make according to CE norms**
按照CE标准制造

SAFETY FEATURES 安全特点

- 1 Top beam design**
车顶防撞设计
- 2 Height limit switch**
上限位开关
- 3 Car door protection**
车门保护垫
- 4 Arm lock engaged automatically when lifting**
升降时自动锁紧托臂
- 5 Foot Protection Device**
防压脚装置
- Dual hydraulic cylinders**
双液缸设置
- Safety valve for anti-explosion of hydraulic system**
安全阀加强安全保护
- Synchronization cables**
同步钢丝绳
- Chain protector**
防脱链装置
- Easy access grease nipple design**
外置润滑油加注口
- Dust protection**
防尘布

STANDARD 标准配置

- Aluminum motor**
铝电机, 耐用, 散热好
- Adjustable lifting pad to two(2) heights**
可调橡胶托垫2节高度
- Three stage arms**
3节臂

OPTIONAL 可选配置

- 70mm 4 PCS**
Optional:Adapters (选配) 增高柱
- 100mm 4 PCS**
Optional:Adapters (选配) 增高柱

DIMENSION 尺寸参数

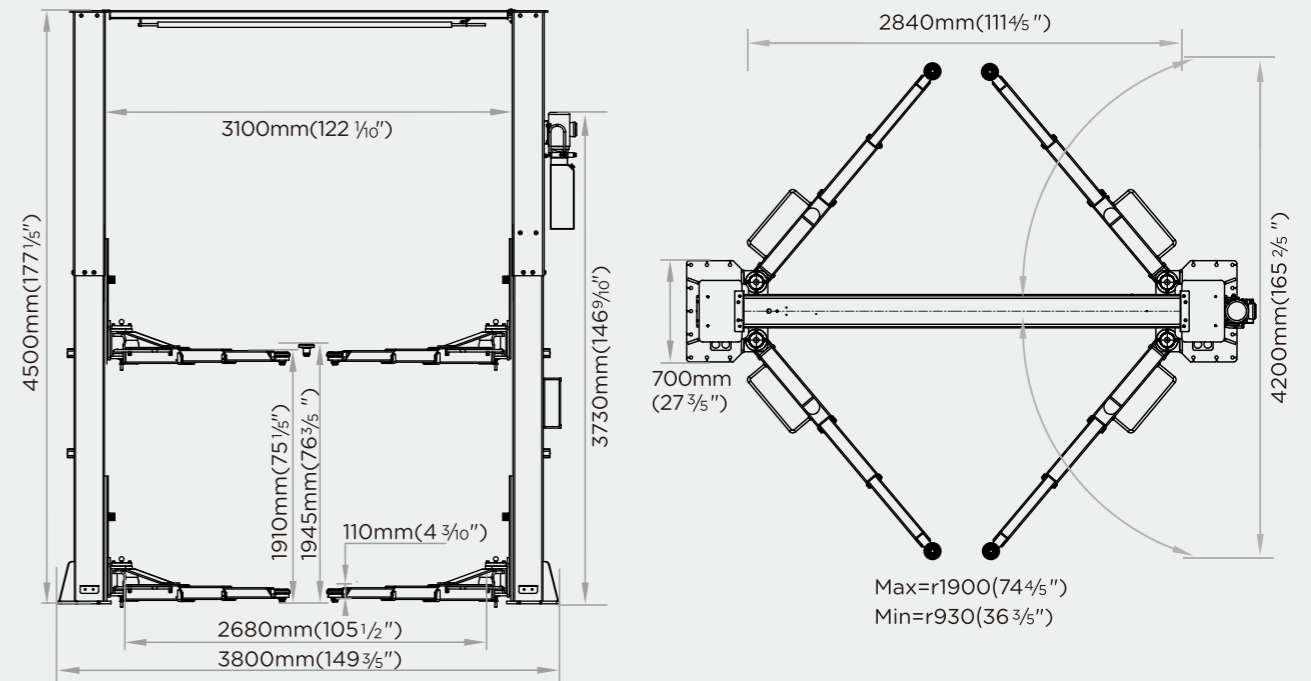

TECHNICAL DATA 技术参数

MODEL 型号	U-T60EB
Capacity 举升重量	6.0 Ton
Lifting height 举升高度	1910mm (75 1/8")
Min height 托臂高度	110mm (4 3/16")
Max car width 通车宽度	2680mm (105 1/2")
Power supply 电源功率	220V/380V 50Hz 3PH 3.0kw
Shipping Information 装运信息	Loading QTY : 12 units/20' CTNR 2900*712*1110mm (1431 kg/units)